

# SAFE-GAUGE®

- WORK SMART · STAY SAFE -



## Technical Data Sheet



Maximise  
Safety



Eliminate  
Live Work



Wireless up to  
100m (328ft)



Purpose Built for  
Heavy Industry

### Overview

The **SafeGauge Tachometer (TM)** enables completely wireless measurement of RPM. It removes technicians from the live work area, greatly reducing the risk of injury.

This rugged, non-contact laser tachometer is designed to achieve fast and accurate measurements in the harshest mining environment. Use the MultiTool Pro to capture multiple RPM measurements at the same time.

### Applications

Speed measurements on:

- Engine cooling fans
- Pulleys and belts
- Turbines or other spinning components

### Features

- Measures up to 10,000 RPM
- Accuracy of +/- 0.01% of reading
- On target indicator
- Rugged IP rated design
- Stainless steel laser housing
- Up to 100m (328ft) Bluetooth range
- Visible Class 2 red laser
- Up to 1.5m (5ft) laser operating distance

**Specifications:**

<b>Electrical</b>	
Power connector	USB Type-C (5V)
Battery technology	Internal LiPo (Lithium Polymer) 3.7 volt pack
Battery life cycle	1000 cycles
Charging	Charge only with SafeGauge charging case
Charging time	4 hours
Operating time	12 hours

<b>Mechanical</b>	
Weight	290g (10oz) without magnetic mounting base (520g (18oz) with magnetic mounting base)
Housing material	Communication box: ABS plastic Laser: 316 stainless steel
Ingress protection	IP67
Operating range	Tested range: 0.1 - 1.5m (0.3 - 4.9ft) Tested angles: 15° to 45° off target
Visible red laser specifications	Laser Wavelength: 650nm Laser Diode Life: 8,000 operating hours MTBF Classification: Class 2 (Per IEC 60825-1:2014) This product complies with IEC 60825-1 Ed. 3 and 21 CFR 1040.10 and 1040.11 except for deviations pursuant to Laser Notice No 50 of June 2007
Accuracy	+/- 0.01% of reading
Reflective materials	Use only with reflective tape supplied by SafeGauge. Other tapes have different reflective properties and may give inaccurate results.
Sensor operating temperature	-10 - 50°C (14 - 122°F)
Sensor charging temperature	0 - 45°C (32 - 113°F)

<b>Communication + Interface</b>	
Communication type	Bluetooth low energy 2.4GHz
Maximum range	Up to 100m (328ft) line of sight
Sample Rate	8Hz
LED system	Communications box: Power LED flashes blue when searching to connect, and green when connected. Laser: LED flashes red when laser is on, and doesn't shine when laser is off Laser: Green when laser is on-target
Button system	During charging: Buttons have no function Operation: • Power button turns device on/off • Laser button turns laser on/off

<b>Environmental</b>	
Battery disposal	When finished with a SafeGauge product please return to SafeGauge Pty Ltd for correct recycling, or follow your local area laws and guidelines for correct battery disposal.

DISCLAIMER - While every effort has been made to ensure the accuracy of this document at the date of issue, SafeGauge assumes no liability resulting from any omissions or errors in this document, and reserves the right to revise content at any time.

**Dimensions**

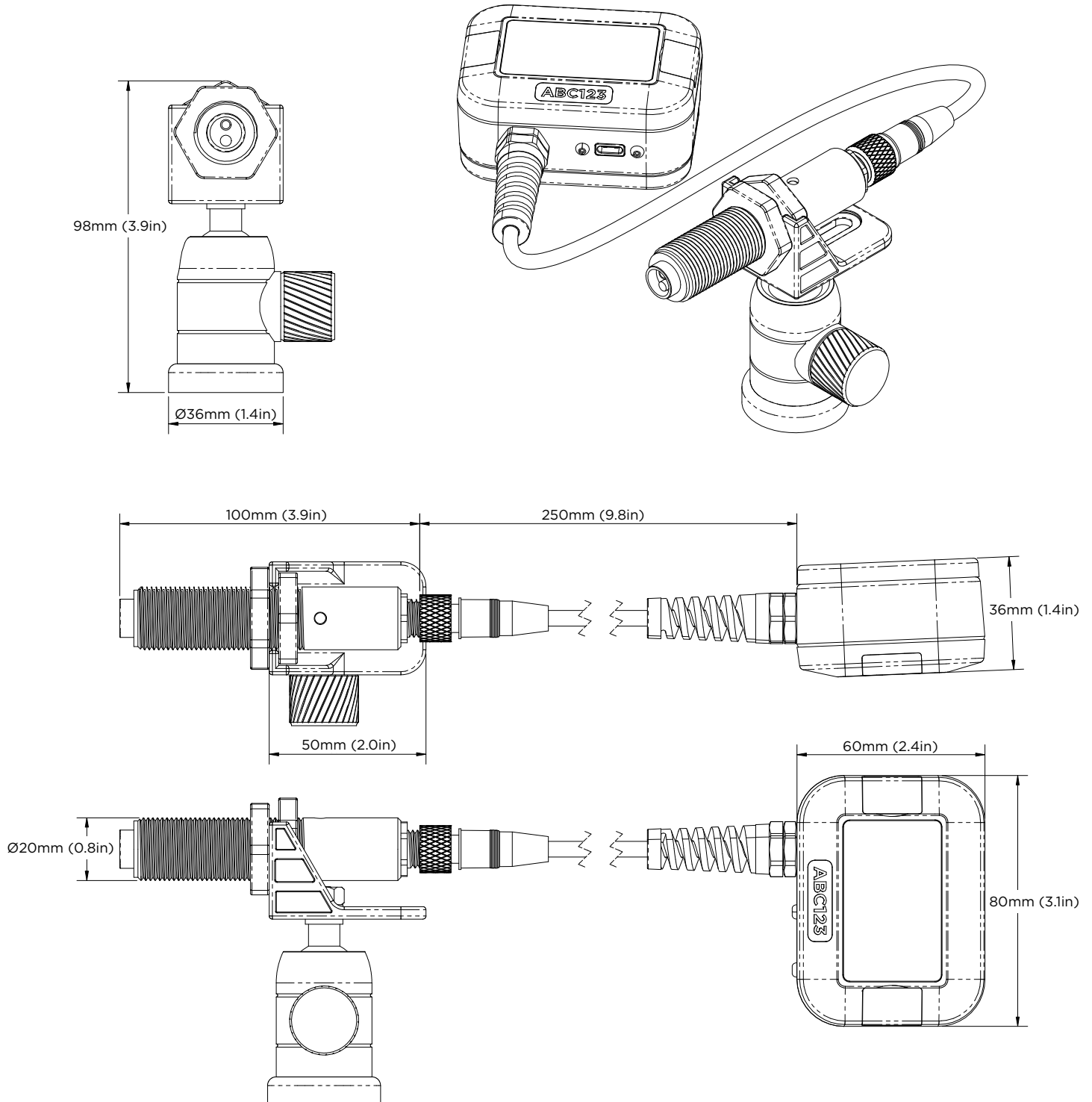

DISCLAIMER - While every effort has been made to ensure the accuracy of this document at the date of issue, SafeGauge assumes no liability resulting from any omissions or errors in this document, and reserves the right to revise content at any time.